

Silicon Carbide MOSFET

750V, 40mΩ SiC MOSFET – Falcon M2 Series



Features

- Optimized $R_{DS(on)}$ with Rapid Switching Behavior
- Compatible with Standard Gate Drivers
- Clean Kelvin-Source Switching Pin-out (TO-247-4L)
- High Avalanche Endurance Capability
- Optimized for High Power Density Applications
- RoHS Compliant and Halogen Free

Potential Applications

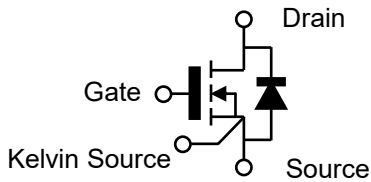

- Switching Mode Power Supply
- PFC & DC/DC Converter
- Portable Adaptor
- Renewable Energy
- Power Inverter
- Motor Driver

Product Information:



Benefits

- Higher System Efficiency
- Increase Parallel Device Convenience
- Enable High Temperature Application
- Allow High Frequency Operation
- Realize Compact and Lightweight Systems
- High Reliability

Product Information	Packaging Type		
	TO-247-3L	TO-247-4L	TO-220-3L
			
Gate	1	4	1
Drain	2, Tab	1	2, Tab
Source	3	2	3
Kelvin Source	--	3	--
Part Number	FF07040M2E-3	FF07040M2Q	FF07040M2C
Marking	FF07040M2	FF07040M2	FF07040M2
Continuous Drain Current	54A	54A	56A
Power Dissipation	200W	200W	220W

Key Performance Parameters

Parameter	Symbol	Value	Unit
Drain-Source Voltage	$V_{DS @ T_{j(max)}}$	750	V
Recommended Gate-Source Turn-On Voltage	V_{GS}	12~15	
Drain-Source On-State Resistance	$R_{DS(on)}$	40	mΩ
Pulse Drain Current	$I_{D, pulse}$	125	A
Avalanche Energy	E_{AS}	520	mJ
Gate Charge	Q_G	66.8	nC
Output Capacitive Charge	Q_{oss}	67.8	
Junction & Storage Temperature	T_j, T_{stg}	-55 to 175	°C

For further information about comparable products, please contact (www.fastsic.com).

Maximum Ratings: (T_j = 25°C, unless otherwise specified)

Parameter	Symbol	Min.	Typ.	Max.	Unit	Test Conditions
Drain-Source Voltage	V_{DSS}	750	--	--	V	$V_{GS}=0V, I_D=1mA$
Continuous Drain Current	I_D	--	--	56 41	A	$V_{GS}=15V, T_C=25°C$ $V_{GS}=15V, T_C=100°C$
Continuous Body Diode Current	I_S	--	--	42		By package type ¹
Pulse Drain Current	$I_{D,pulse}$	--	--	125		$V_{GS}=0V, T_C=25°C$ Per SOA
Avalanche Energy, Single Pulse	E_{AS}	--	--	520	mJ	$L=25mH$
Operate Gate Source Voltage	$V_{GS,op}$	-8	--	12~15	V	Recommended operating values
Transient Gate Source Voltage	$V_{GS,tran.}$	-9	--	19		Transient operating limit (AC f > 1Hz, pulse width < 100ns)
Junction Temperature	T_j	-55	--	175	°C	
Storage Temperature	T_{stg}	-55	--	175		
Soldering Temperature	T_L	--	--	260		

¹ Per figure section 2~6

Electrical Characteristics:

Parameter	Symbol	Min.	Typ.	Max.	Unit	Test Conditions
DC Characteristics (at T_j = 25°C, unless otherwise specified)						
Drain-source Breakdown Voltage	$V_{(BR)DSS}$	750	--	--	V	$V_{GS}=0V, I_D=1mA, T_j=25°C$
Drain-Source On-State Resistance	$R_{DS(on)}$	--	40	--	mΩ	$V_{GS}=15V, I_D=18A, T_j=25°C$
		--	57	--		$V_{GS}=15V, I_D=18A, T_j=175°C$
		--	52	--		$V_{GS}=12V, I_D=18A, T_j=25°C$
		--	62	--		$V_{GS}=12V, I_D=18A, T_j=175°C$
Gate-Source Threshold Voltage	V_{th}	--	2.5	--	V	$V_{GS}=V_{DS}, I_D=25mA$
Zero Gate Voltage Drain Current	I_{DSS}	--	<1	1000	μA	$V_{DS}=750V, V_{GS}=0V, T_j=25°C$
Gate-Source Leakage Current	I_{GSS}	--	--	100	nA	$V_{GS}=15V, V_{DS}=0V$
Body Diode Forward Voltage	V_{SD}	--	2.7	--	V	$V_{GS}=0V, I_S=9A, T_j=25°C$
		--	2.4	--		$V_{GS}=0V, I_S=9A, T_j=175°C$

AC Characteristics (at T_j = 25°C, unless otherwise specified)

Input Capacitance	C_{iss}	--	2002.3	--	pF	$V_{DS}=400V, V_{GS}=0V,$ $f=250kHz, V_{AC}=25mV$	
Output Capacitance	C_{oss}	--	97.0	--			
Reverse Capacitance	C_{rss}	--	7.4	--			
Effective Output Capacitance, energy related	$C_{o(er)}$ ¹	--	112.5	--			
Effective Output Capacitance, time related	$C_{o(tr)}$ ²	--	169.6	--			
C_{oss} Stored Energy	E_{oss}	--	9.0	--			μJ
Output Capacitive Charge	Q_{oss}	--	67.8	--			nC
Internal Gate Resistance	$R_{G,int.}$	--	2.8	--	Ω	$f=1MHz, V_{AC}=25mV$	

¹ $C_{o(er)}$ is a fixed capacitance that gives the same stored energy as C_{oss} while V_{DS} is rising from 0 to 400V.

² $C_{o(tr)}$ is a fixed capacitance that gives the same charging time as C_{oss} while V_{DS} is rising from 0 to 400V.

Switching Characteristics:

Parameter	Symbol	Min.	Typ.	Max.	Unit	Test Conditions
Gate Characteristics						
Gate to Source Charge	Q_{GS}	--	15.9	--	nC	$V_{DS}=400V, V_{GS}=0V/+15V, I_D=18A$
Gate to Drain Charge	Q_{GD}	--	18.7	--		
Total Gate Charge	Q_G	--	66.8	--		
Inductive Load						
Turn On Delay Time	$t_{d(on)}$	--	25.9	--	ns	$V_{DS}=400V,$ $I_D=16A,$ $V_{GS}=-3/+15V,$ $R_{G(ext.)}=4.7\Omega$
Rise Time	t_r	--	31.2	--		
Turn Off Delay Time	$t_{d(off)}$	--	28.7	--		
Fall Time	t_f	--	11.0	--		
Turn On Switching Energy	E_{on}	--	173.1	--	μJ	
Turn Off Switching Energy	E_{off}	--	24.5	--		
Body Diode Characteristics						
Forward Recovery Charge	Q_{fr}	--	193.2	--	nC	$V_{GS}=0V, I_S=16A, V_{DS}=400V,$ $di/dt=1880A/\mu s$ <i>*Q_{fr} herein excluded the Q_{oss} value.</i>
Forward Recovery Time	t_{fr}	--	18.4	--	ns	
Peak Forward Recovery Current	I_{frm}	--	21.0	--	A	

¹ Test are based on TO-247-4L PKG

Thermal Characteristics:

Parameter	Symbol	Min.	Typ.	Max.	Unit	Test Conditions
Thermal Impedance, junction-case	R_{th-jc}	--	0.75	--	K/W	TO-247-3L
		--	0.75	--		TO-247-4L
		--	0.68	--		TO-220-3L
Thermal Impedance, junction-ambient	R_{th-ja}	--	40	--		Device on PCB, with 6 cm ² of cooling area

1. Electrical Characteristics Diagrams

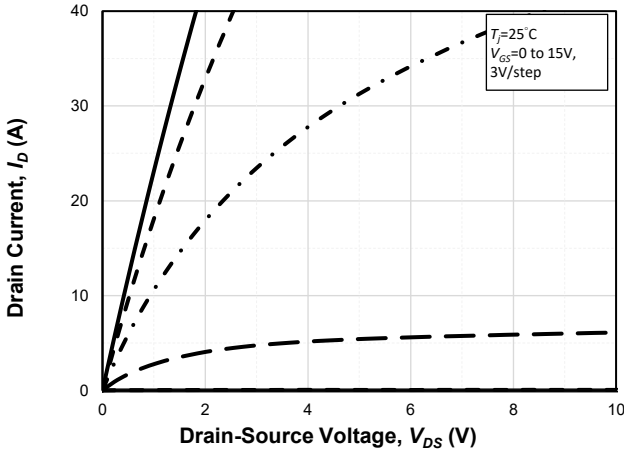

Fig. 1-1 Typical Output Characteristics at $T_j=25^\circ\text{C}$

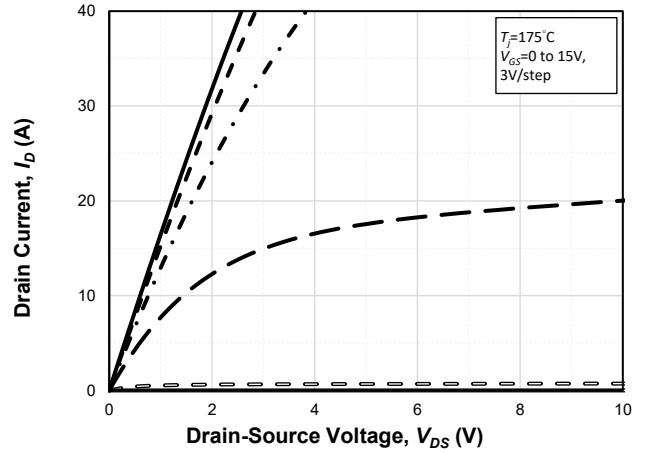

Fig. 1-2 Typical Output Characteristics at $T_j=175^\circ\text{C}$

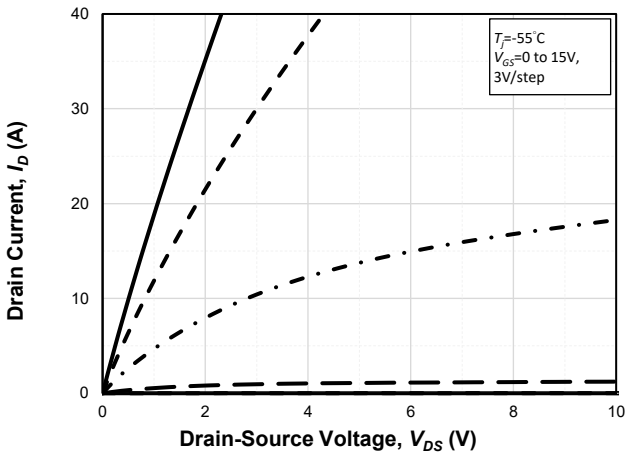

Fig. 1-3 Typical Output Characteristics at $T_j=-55^\circ\text{C}$

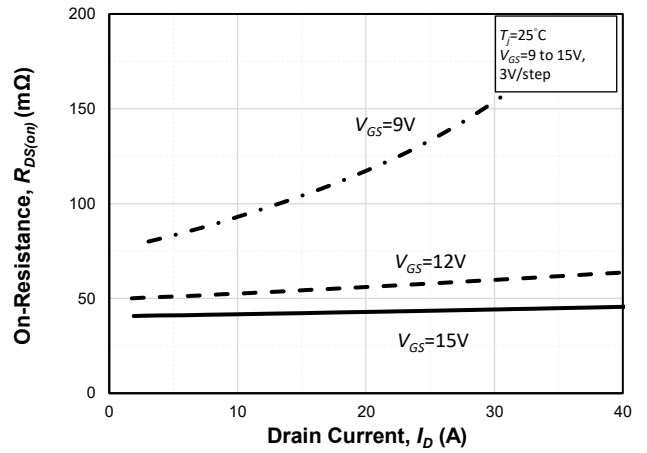

Fig. 1-4 Typ. $R_{DS(on)}$ vs. I_D with Various V_{GS}

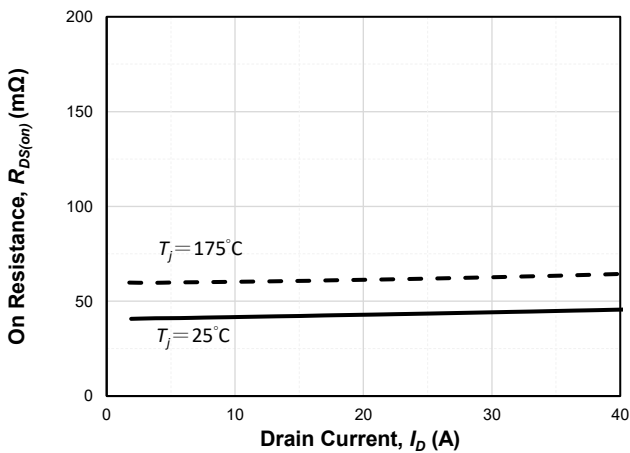

Fig. 1-5 Typ. $R_{DS(on)}$ vs. I_D with Various T_j , $V_{GS}=15\text{V}$

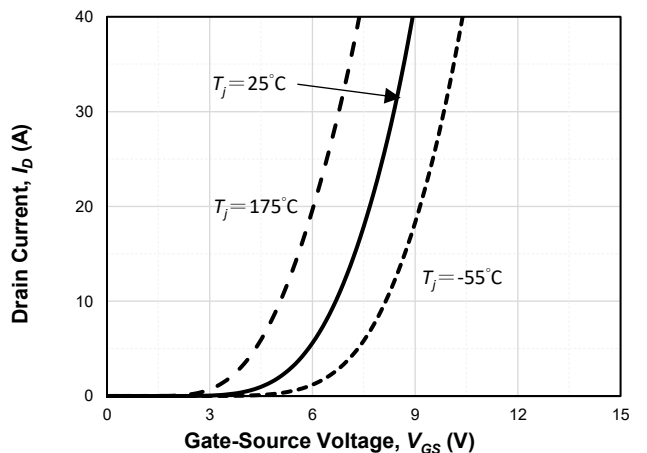

Fig. 1-6 Typ. I_D vs. V_{GS} with Various T_j , $V_{DS}=10\text{V}$

1. Electrical Characteristics Diagrams

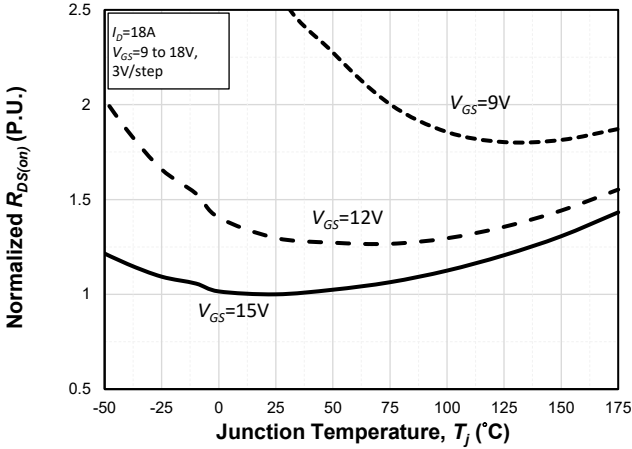

Fig. 1-7 Normalized $R_{DS(on)}$ vs. T_j with Various V_{GS}

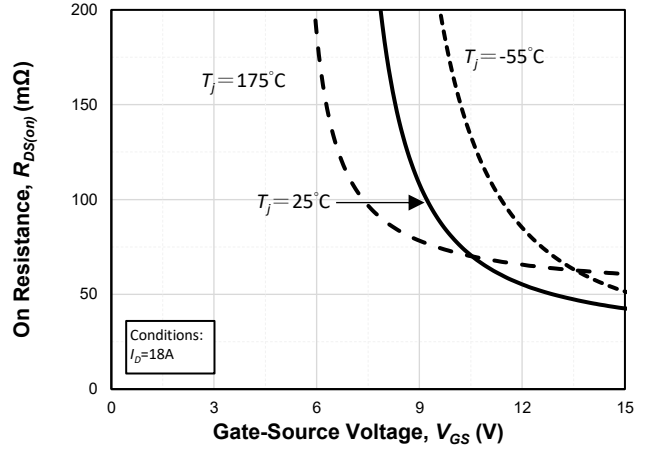

Fig. 1-8 Typ. $R_{DS(on)}$ vs. V_{GS} with Various T_j

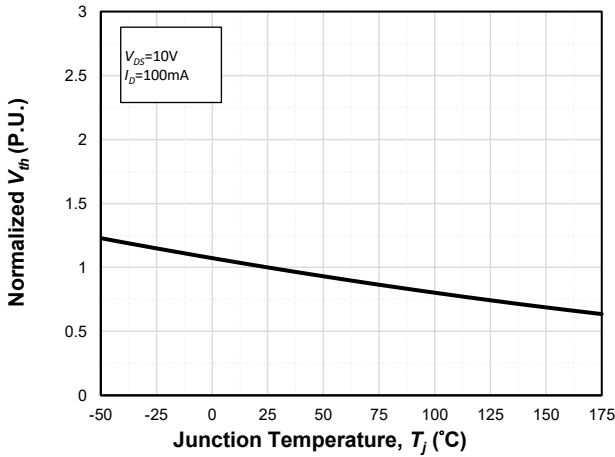

Fig. 1-9 Normalized V_{th} vs. T_j

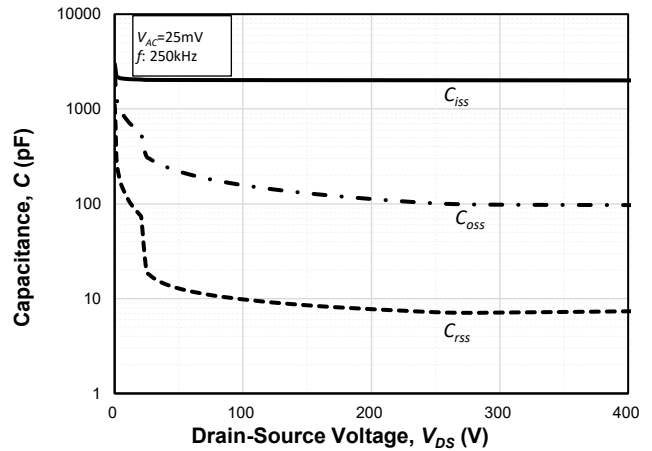

Fig. 1-10 Typ. Capacitance vs. V_{DS} at $f_{sw}=250kHz$

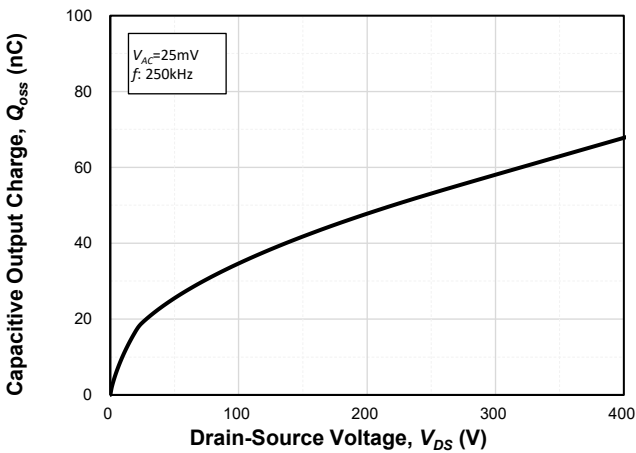

Fig. 1-11 Typ. Capacitive Output Charge at $f_{sw}=250kHz$

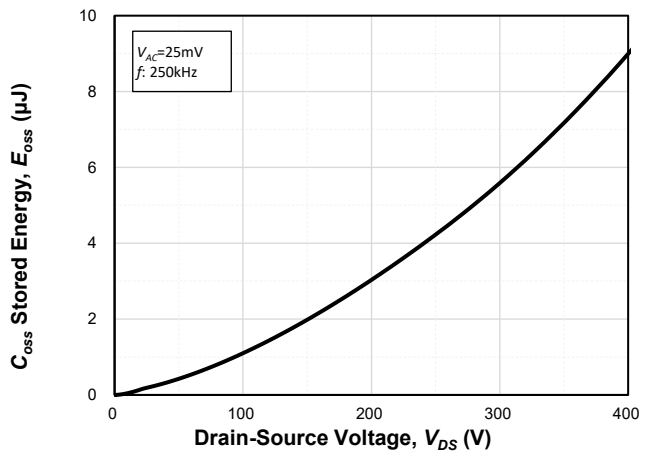

Fig. 1-12 Typ. C_{oss} Stored Energy at $f_{sw}=250kHz$

1. Electrical Characteristics Diagrams

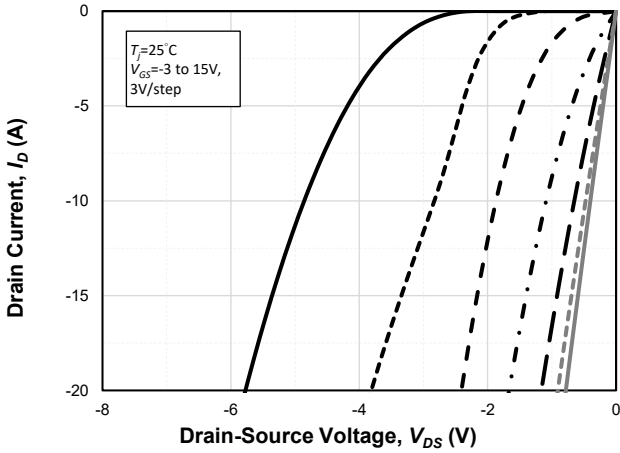

Fig. 1-13 Typical Forward Characteristics of Reverse Conduction at $T_j=25^\circ\text{C}$

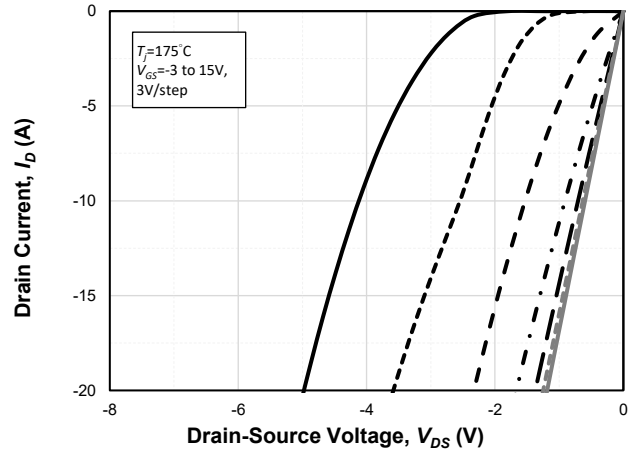

Fig. 1-14 Typical Forward Characteristics of Reverse Conduction at $T_j=175^\circ\text{C}$

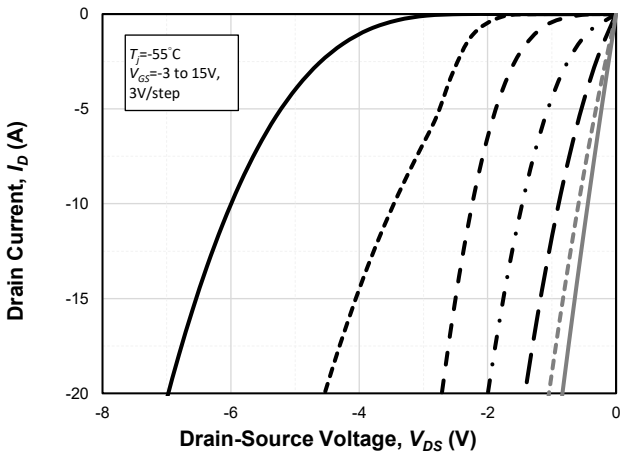

Fig. 1-15 Typical Forward Characteristics of Reverse Conduction at $T_j=-55^\circ\text{C}$

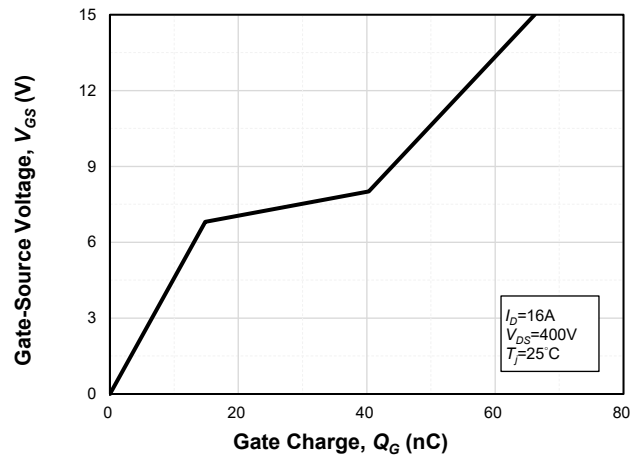

Fig. 1-16 Typ. Gate Charge

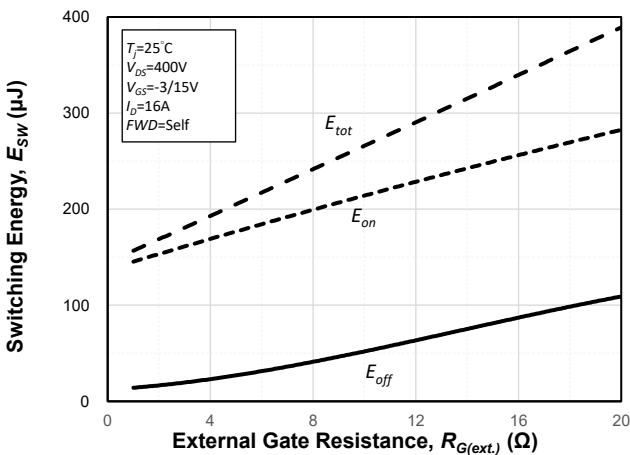

Fig. 1-17 Typ. Switching Energy vs. I_D

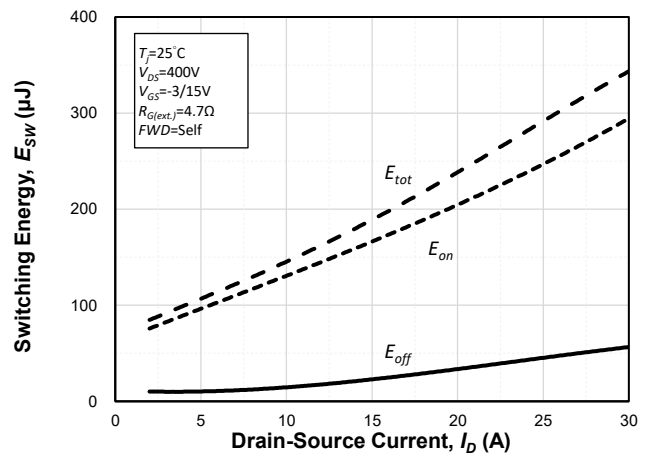

Fig. 1-18 Typ. Switching Energy vs. $R_{G(ext.)}$

2. Drain Power Dissipation

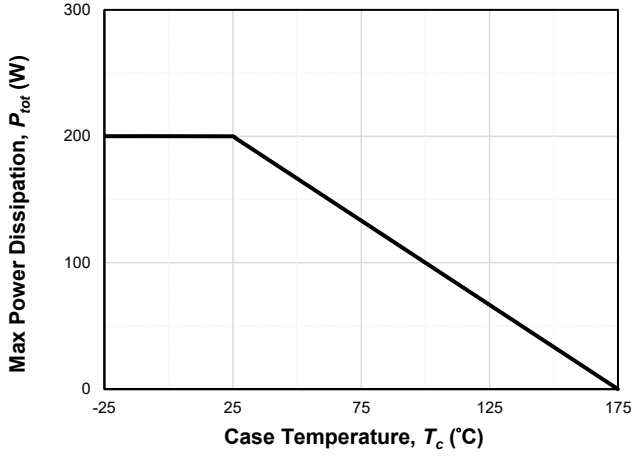

Fig. 2-1 Power Dissipation at $V_{GS}=15V, T_j \leq 175^\circ C$ (TO-247-3L)

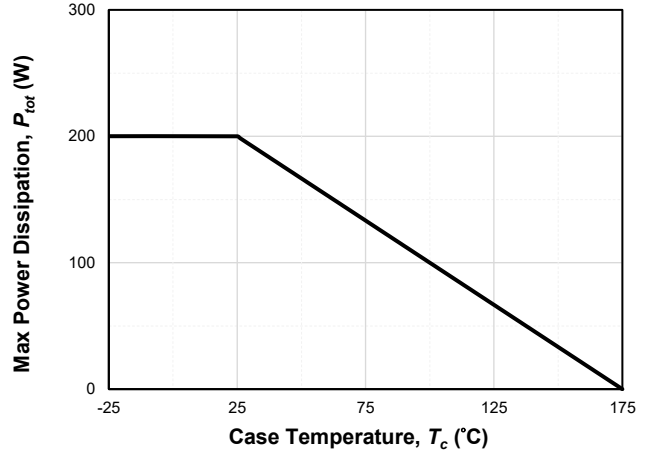

Fig. 2-2 Power Dissipation at $V_{GS}=15V, T_j \leq 175^\circ C$ (TO-247-4L)

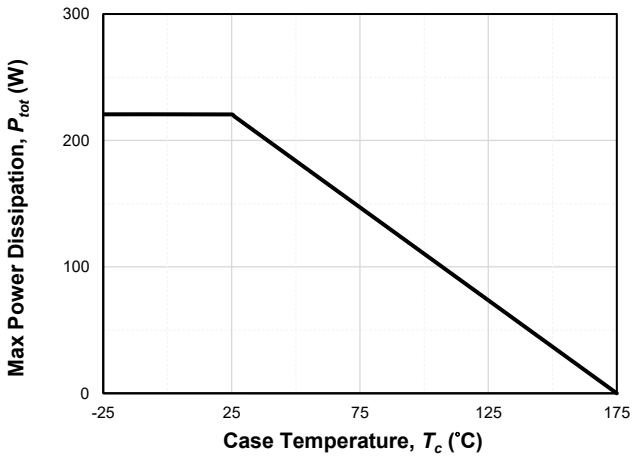

Fig. 2-3 Power Dissipation at $V_{GS}=15V, T_j \leq 175^\circ C$ (TO-220-3L)

3. Drain Current Dissipation

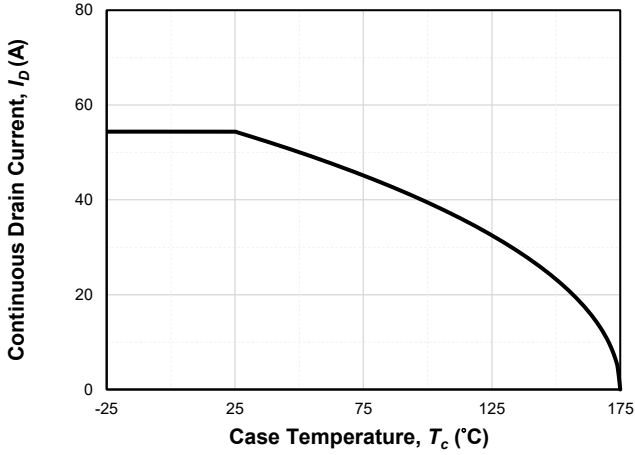

Fig. 3-1 Current Dissipation at $V_{GS}=15V$, $T_j \leq 175^\circ C$ (TO-247-3L)

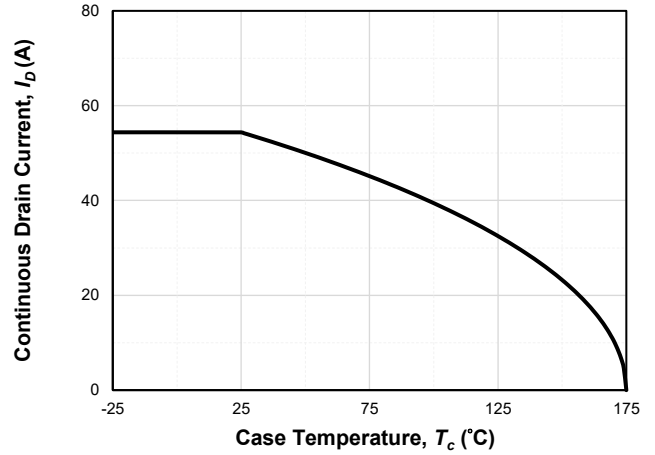

Fig. 3-2 Current Dissipation at $V_{GS}=15V$, $T_j \leq 175^\circ C$ (TO-247-4L)

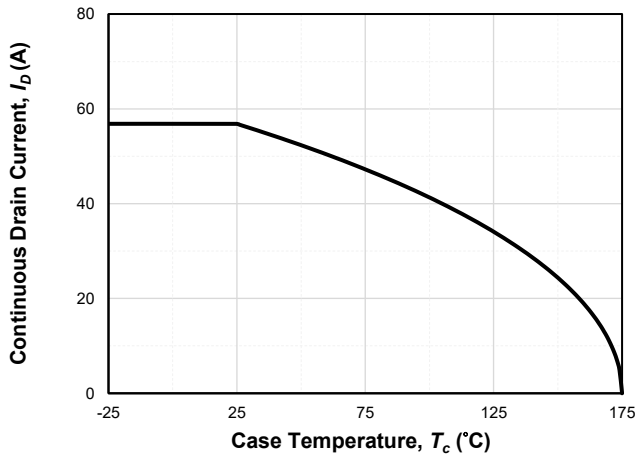

Fig. 3-3 Current Dissipation at $V_{GS}=15V$, $T_j \leq 175^\circ C$ (TO-220-3L)

4. Body Diode Current Dissipation

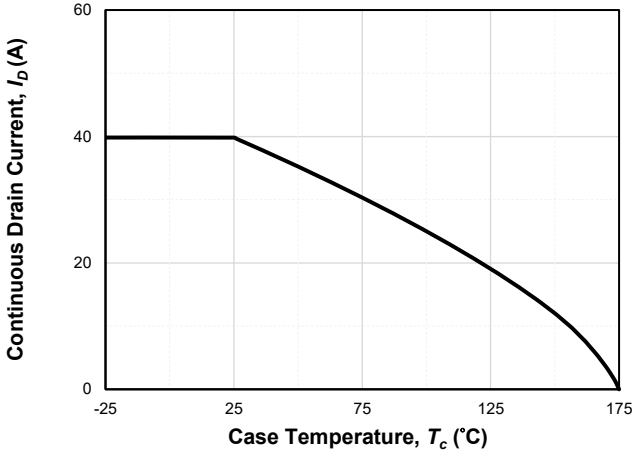

Fig. 4-1 Body Diode Current Dissipation at $V_{GS}=0V$, $T_j \leq 175^\circ C$ (TO-247-3L)

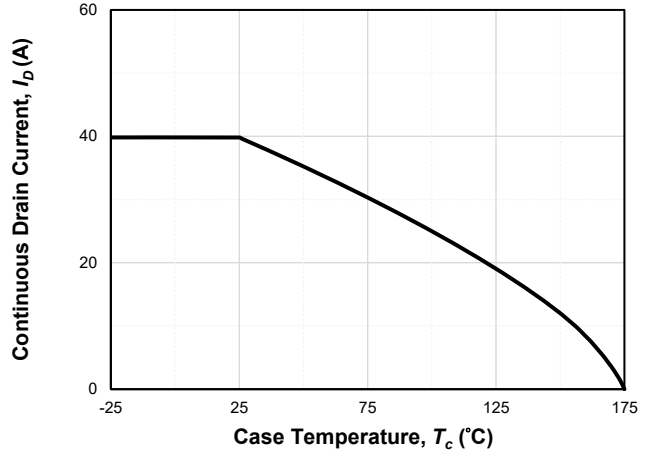

Fig. 4-2 Body Diode Current Dissipation at $V_{GS}=0V$, $T_j \leq 175^\circ C$ (TO-247-4L)

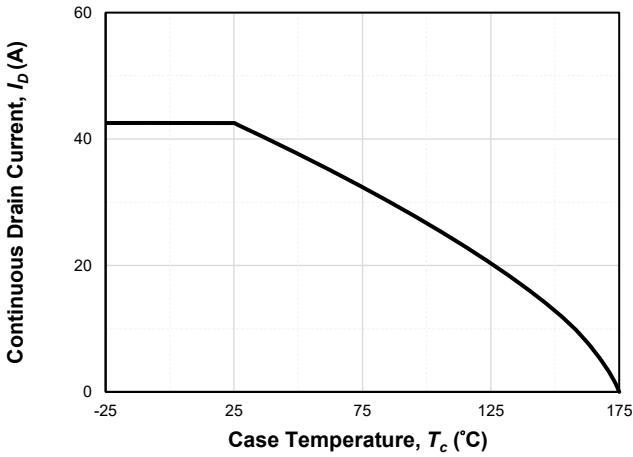

Fig. 4-3 Body Diode Current Dissipation at $V_{GS}=0V$, $T_j \leq 175^\circ C$ (TO-220-3L)

5. Thermal Impedance

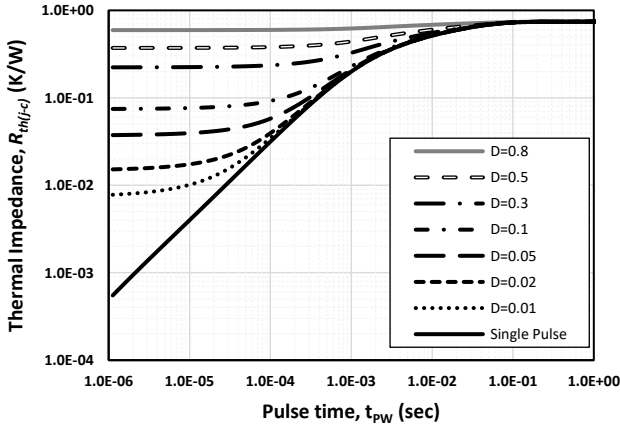

Fig. 5-1 Typ. Transient Thermal Impedance R_{th-jc} (TO-247-3L)

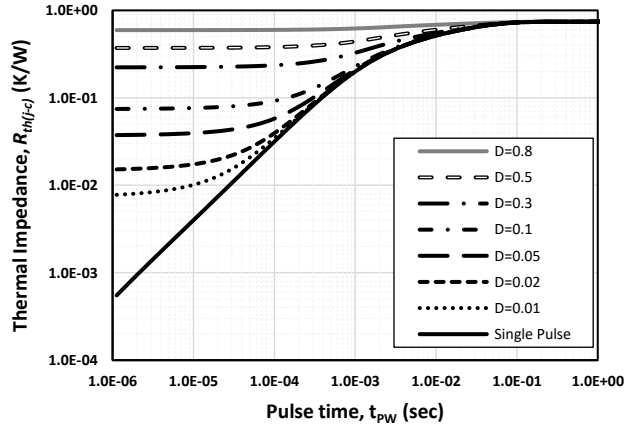

Fig. 5-2 Typ. Transient Thermal Impedance R_{th-jc} (TO-247-4L)

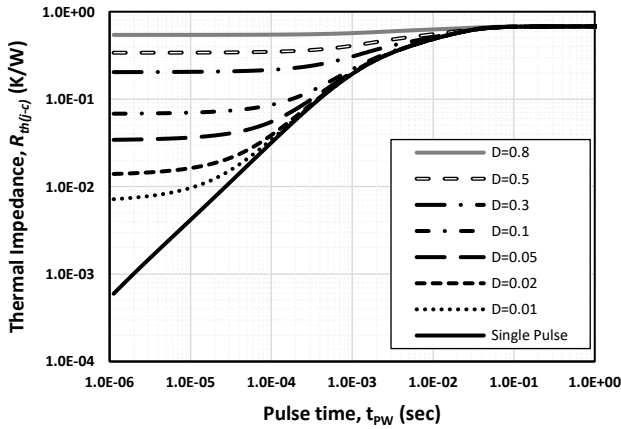

Fig. 5-3 Typ. Transient Thermal Impedance R_{th-jc} (TO-220-3L)

6. Safe Operating Area (25°C)

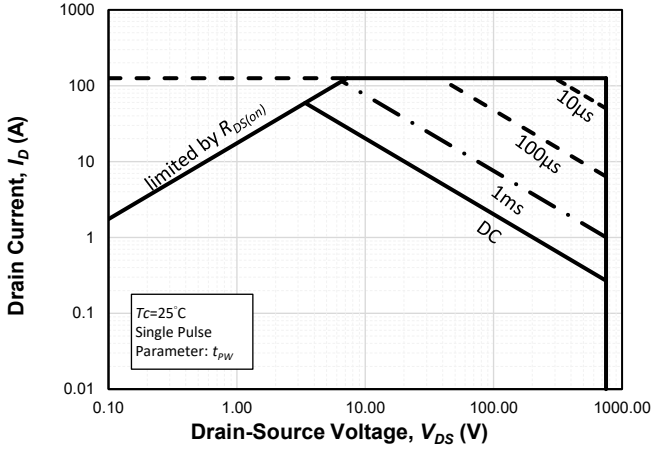

Fig. 6-1 Safe Operating Area at $T_c=25^\circ\text{C}$ (TO-247-3L)

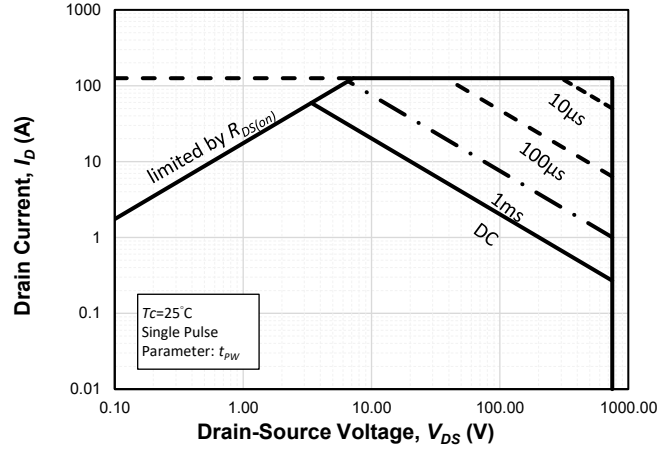

Fig. 6-2 Safe Operating Area at $T_c=25^\circ\text{C}$ (TO-247-4L)

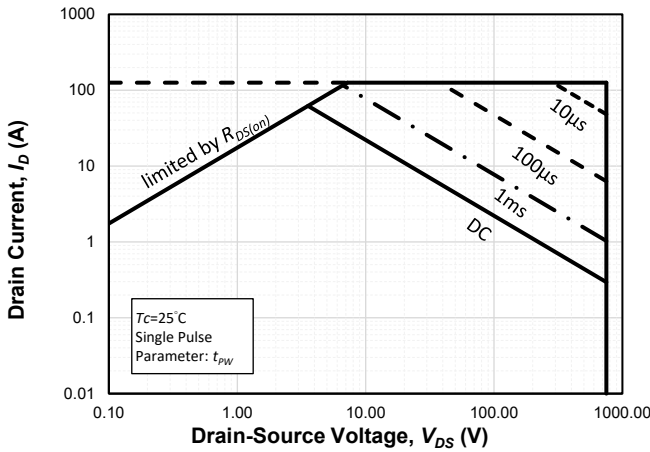

Fig. 6-3 Safe Operating Area at $T_c=25^\circ\text{C}$ (TO-220-3L)

7. Safe Operating Area (100°C)

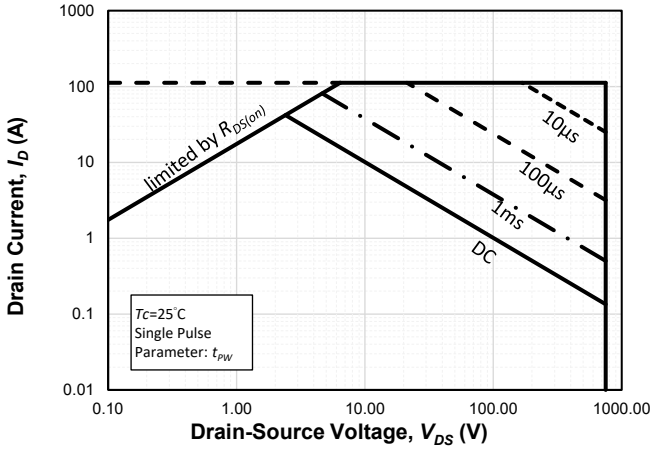

Fig. 7-1 Safe Operating Area at $T_c = 100^\circ\text{C}$ (TO-247-3L)

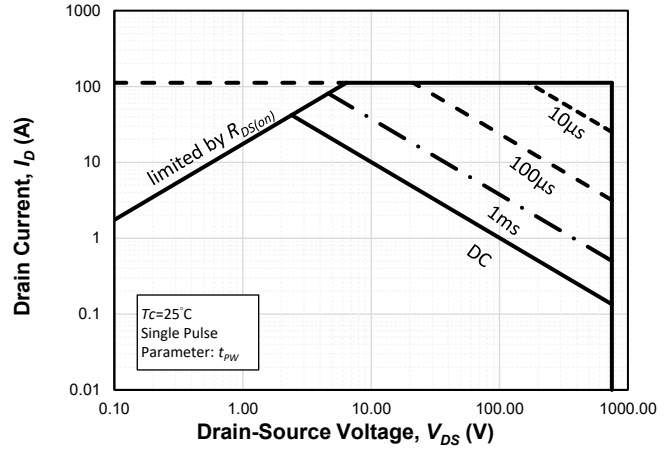

Fig. 7-2 Safe Operating Area at $T_c = 100^\circ\text{C}$ (TO-247-4L)

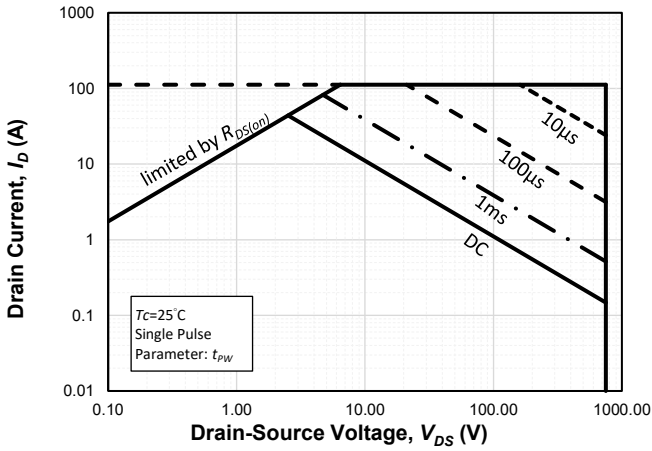
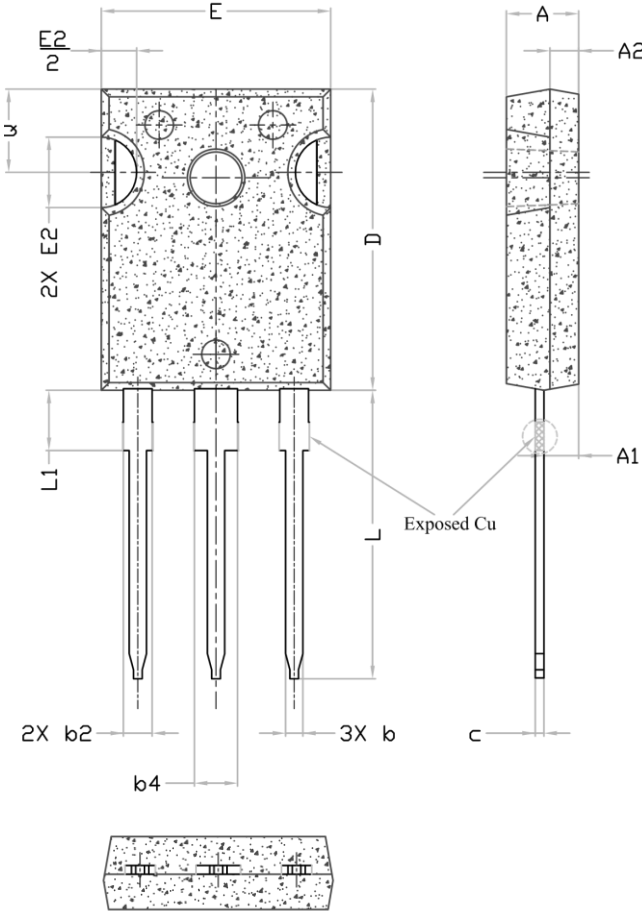

Fig. 7-3 Safe Operating Area at $T_c = 100^\circ\text{C}$ (TO-220-3L)

Package Outline (TO-247-3L)



Symbol	Dimension (Millimeters)		
	Min.	Nom.	Max.
A	4.83	5.02	5.21
A1	2.29	2.41	2.55
A2	1.50	2.00	2.49
b	1.12	1.20	1.33
b1	1.12	1.20	1.28
b2 ⁽⁴⁾	1.91	2.00	2.39
b3	1.91	2.00	2.34
b4 ⁽⁴⁾⁽⁶⁾	2.87	3.00	3.22
b5	2.87	3.00	3.18
c ⁽⁴⁾	0.55	0.60	0.69
c1	0.55	0.60	0.65
D ⁽²⁾	20.80	20.95	21.10
D1 ⁽³⁾	16.25	16.55	17.65
D2	0.51	1.19	1.35
E ⁽²⁾	15.75	15.94	16.13
E1 ⁽³⁾	13.46	14.02	14.16
E2 ⁽¹⁾	4.32	4.91	5.49
e	5.44 BSC.		
L	19.81	20.07	20.32
L1 ⁽⁴⁾	4.10	4.19	4.40
φP ⁽⁵⁾	3.56	3.61	3.65
φP1	7.19 REF.		
Q	5.39	5.79	6.20
S	6.04	6.17	6.30

Note:

1. Slot required, notch may be rounded.
2. Dimension D & E do not include mold flash. Mold flash shall not exceed 0.127mm pre side. These dimensions are measured at the outermost extreme of the plastic body.
3. Thermal pad contour optional within dimension D1 & E1.
4. Lead finish uncontrolled in L1.
5. φP to have a maximum draft angle of 1.5° to the top of the part with a maximum hole diameter of 3.91mm.
6. Dimension “b2” and “b4” does not include dambar protrusion. Allowable dambar protrusion shall be 0.10mm total in excess of “b2” and “b4” dimension at maximum material condition.

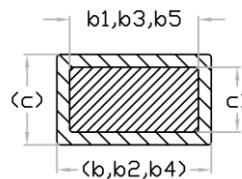
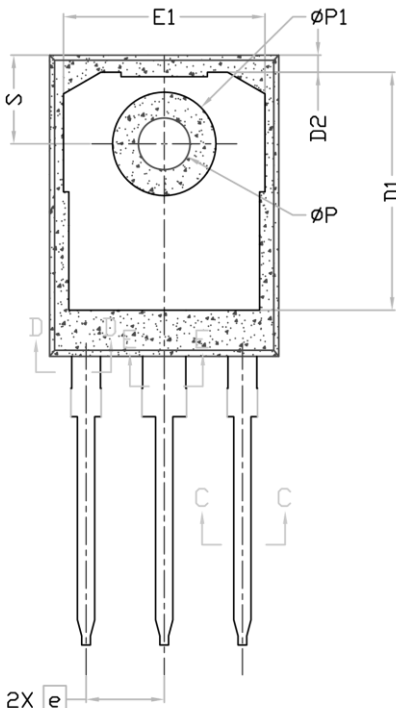

Section C--C, D--D, E--E

Package Outline (TO-247-4L)

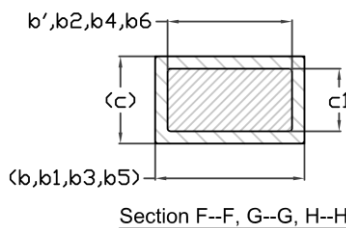
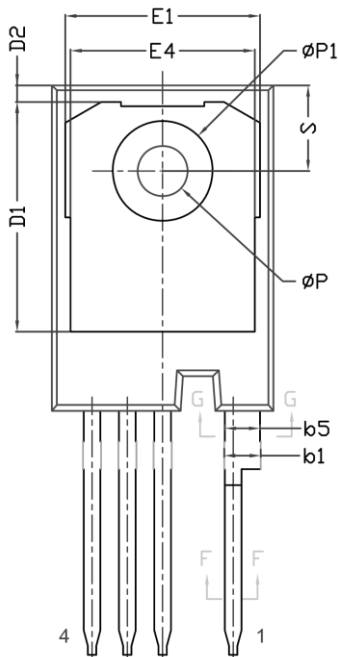
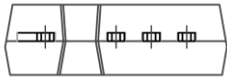
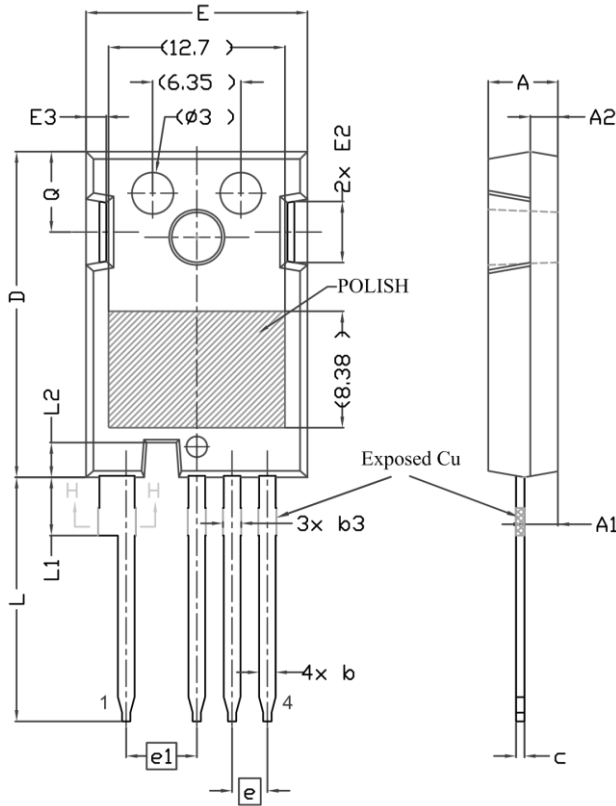

Symbol	Dimension (Millimeters)		
	Min.	Nom.	Max.
A	4.83	5.02	5.21
A1	2.29	2.41	2.54
A2	1.91	2.00	2.16
b'	1.07	1.20	1.28
b	1.07	1.20	1.33
b1	2.39	2.67	2.94
b2	2.39	2.67	2.84
b3	1.07	1.30	1.60
b4	1.07	1.30	1.50
b5	2.39	2.53	2.69
b6	2.39	2.53	2.64
c	0.55	0.60	0.68
c1	0.55	0.60	0.65
D	23.30	23.45	23.60
D1	16.25	16.55	17.65
D2	0.95	1.19	1.25
E	15.75	15.94	16.13
E1	13.10	14.02	14.15
E2	3.68	4.40	5.10
E3	1.00	1.45	1.90
E4	12.38	13.26	13.43
e	2.54 BSC.		
e1	5.08 BSC.		
L	17.31	17.57	17.82
L1	3.97	4.19	4.37
L2	2.35	2.50	2.65
ϕP	3.51	3.61	3.65
$\phi P1$	7.19 REF.		
Q	5.49	5.79	6.00
S	6.04	6.17	6.30

Note:

1. Slot required, notch may be rounded.
2. Dimension D & E do not include mold flash. Mold flash shall not exceed 0.127mm pre side. These dimensions are measured at the outermost extreme of the plastic body.
3. Thermal pad contour optional within dimension D1 & E1.
4. Lead finish uncontrolled in L1.
5. ϕP to have a maximum draft angle of 1.5° to the top of the part with a maximum hole diameter of 3.91mm.

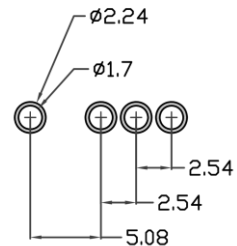

Recommended Solder Pad Layout

Package Outline (TO-220-3L)

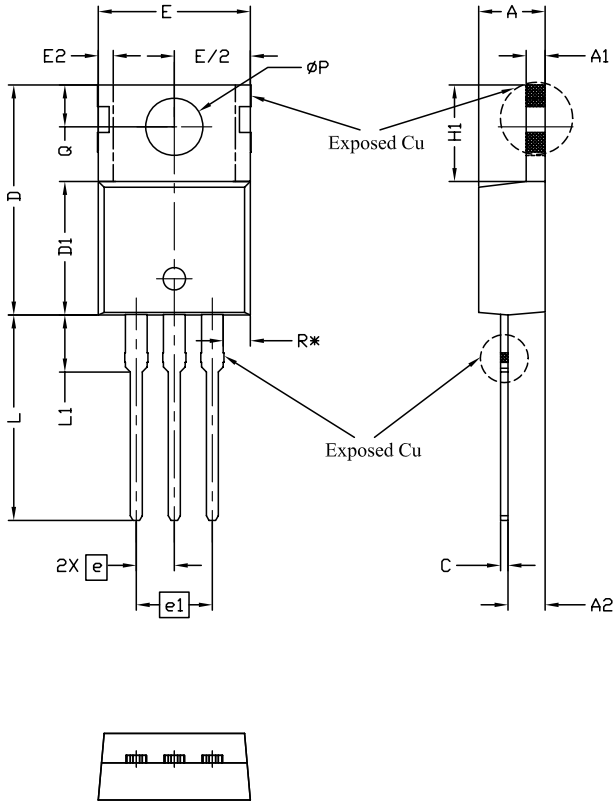

Symbol	Dimension (Millimeters)		
	Min.	Nom.	Max.
A	4.24	4.44	4.64
A1	1.15	1.27	1.40
A2	2.30	2.48	2.70
b	0.70	0.80	0.90
b1	1.20	1.55	1.75
b2	1.20	1.45	1.70
c	0.40	0.50	0.60
D ⁽²⁾	14.70	15.37	16.00
D1	8.82	8.92	9.02
D2 ⁽³⁾	12.43	12.73	12.83
E ^{(2), (3)}	9.96	10.16	10.36
E1 ⁽³⁾	6.86	7.77	8.89
E2 ⁽⁴⁾	--	--	0.76
E3*	8.70 REF.		
e	2.54 BSC.		
e1	5.08 BSC.		
H1 ^{(3), (4)}	6.30	6.45	6.60
L	13.47	13.72	13.97
L1	3.60	3.80	4.00
ØP	3.75	3.84	3.93
Q	2.60	2.80	3.00
Q1*	1.73 REF.		
R*	1.82 REF.		

Note:

1. Slot required; notch may be rounded.
2. Dimension D & E do not include mold flash. Mold flash shall not exceed 0.127mm pre side. These dimensions are measure at the outermost extreme of the plastic body.
3. Thermal pad contour optional within dimensions E, H1, D2 & E1.
4. Dimension E2 & H1 define a zone where stamping and singulation irregularities are allowed.
5. "*" is for reference.

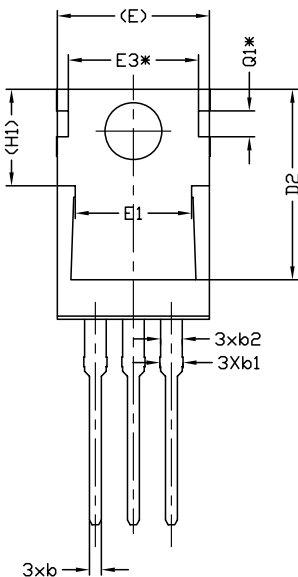

Revision History

Date	Revision	Changes
26.02	Preliminary	1 st issue

Important Note (Disclaimer)

Fast SiC Semiconductor Inc. (“FSS”) reserves the right to make changes and improvements to this product and the information provided in this document may be subject to change without prior notice. Buyers should contact FSS sales representatives to obtain the latest information on this product before placing order and are solely responsible for the selection and use of this product. In addition, any information given in this document is only intended to show the typical functions that can vary in different applications and shall not be regarded as a guarantee or warranty of conditions or characteristics.

This product is not designed or intended for use for applications in which the failure of the product could lead to personal injury, death or property damage, including but not limited to equipment used in medical systems, traffic communication or control systems, transportations (cars, ships, trains) and aerospace. FSS shall have no responsibility for any damages or injury arising from non-compliance with the recommended usage conditions provided herein.

Published by:
Fast SiC Semiconductor Inc.
Hsinchu, Taiwan
©2026 fast SiC Semiconductor Inc.
All Rights Reserved.